

Highlights:

- Punched square holes for use with snap-in cage nuts
- 482 mm usable depth
- Protects & transports up to 16 units of 19" equipment
- Detachable front & rear cover
- ProShield™ Heavy duty top layer
- High quality 9 mm plywood
- Hardware by Penn Elcom
- Dual perforated rack rail on both sides (MK2 version)

The FC116 is a 16 unit professional double cover flightcase compliant to the ANSI/EIA RS-310D, DIN41491 and IEC60297 standards for 19" equipment installation. The construction is made out of high quality 9 mm plywood covered by a ProShield™ top layer, offering optimal protection for your equipment. Both front and back lids are detachable, allowing instant access to both controls and connections of your equipment. Mounting of the equipment can be done using the perforated rack rail with punched square holes for use with snap-in cage nuts, while the dual structure allows installation of horizontal supports for heavy equipment. Superior durability and handling convenience is guaranteed through Penn-Elcom® hardware such as heavy-duty ball corners, rivet protected recessed flip handles and MOL™ type butterfly latches.



Product Features:

Dimensions		529 x 744 x 687 mm (W x H x D) (excl. rubber feet)
Unit height		16 HE
Tunnel depth		507 mm (excl. covers)
Max. usable depth		482 mm
Weight		32.620 kg
Construction		9 mm high-quality plywood
Finish		ProShield™ top layer
Handles		4 x Medium heavy-duty (Penn Elcom H7154Z)
Latches		8 x Medium MOL™ (Penn Elcom L907/928/10)
Accessories	Optional	KM600 - M6 Cage nuts
		KS600 - M6 x 16 mm bolt DIN7985 Black
		KM500 - M5 Cage nuts
		KS500 - M5 x 16 mm bolt DIN7985 Black
		SPR60LR - L-rail (horizontal support)
		FCB104 - Caster board (530 x 560 mm)
		BSFxxx - 19" blind panels (1 to 6U)
		BSVxxx - 19" ventilated blind panels (1 to 6U)

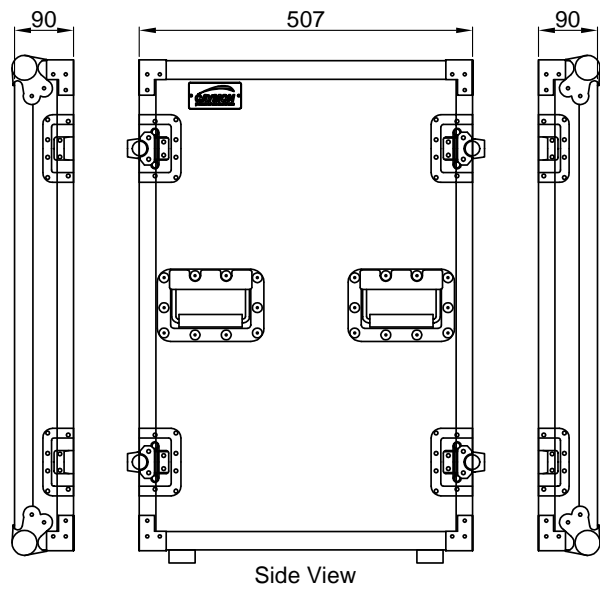
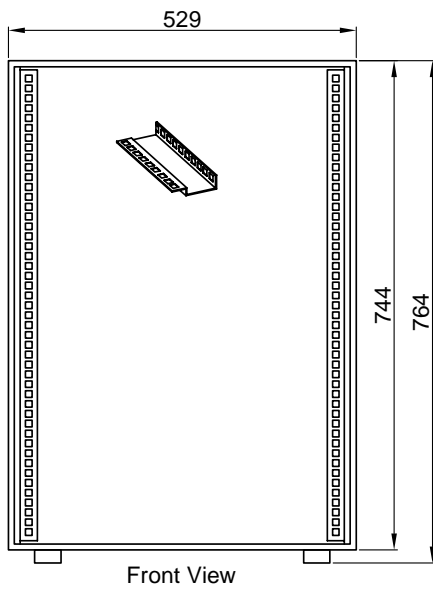
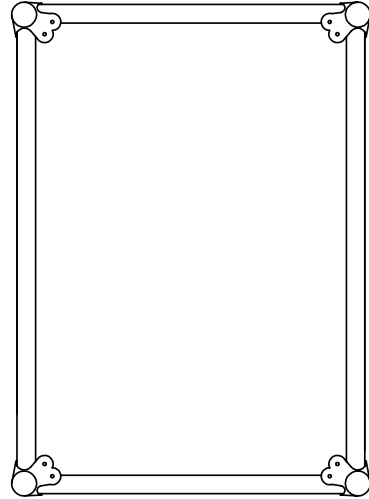
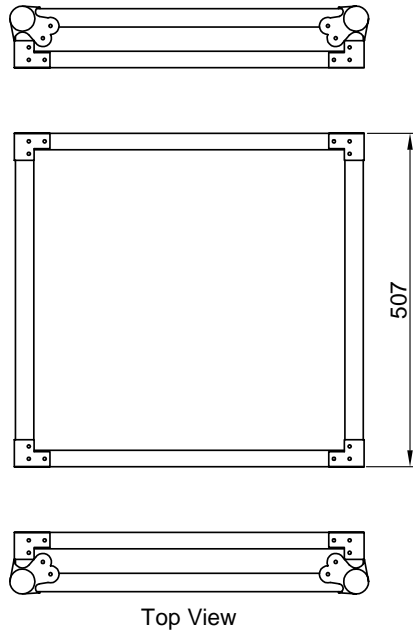

	<h2>FC116</h2>	Product description: PROFESSIONAL FLIGHTCASE - SEPARATE FRONT AND REAR COVER - 16 UNITS	
	Weight: TBA	Outer dimensions: (w x h x d) 529 x 764 x 687	Unit height: 16 HE